

Sequential Multipoint injection 3-4 cyl

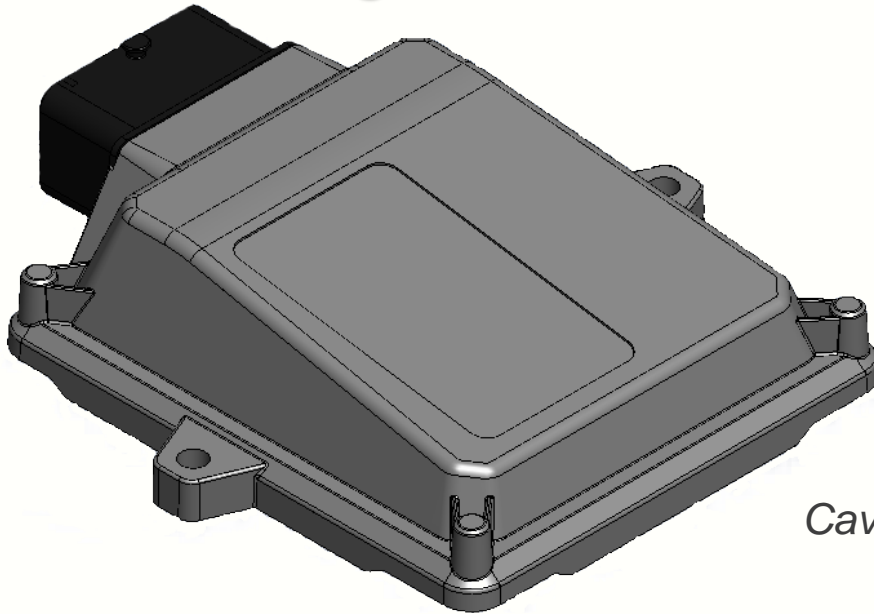

Beltrami Marco

Cavriago, 11th October 2011



- ❑ Supply voltage: $V_{\text{batt}} = 10 \div 16\text{V}$
- ❑ Working Temperature Range: $-40 \div 105^{\circ}\text{C}$
- ❑ Quiescent current (actuators inhibited): $I_{\text{max}} \leq 0.5\text{A}$
- ❑ Quiescent Current in standby: $I_{\text{standby}} \leq 5\text{mA}$
- ❑ Injectors: $I_{\text{max}} = 6\text{A}$, $V_{\text{batt,max}} = 16\text{V}$
- ❑ Gas Valves (2 output):
 - $P_{\text{max}} = 50\text{W}$, $I_{\text{max}} = 4\text{A}$ (single common output)
 - $P_{\text{max}} = 25\text{W}$, $I_{\text{max}} = 2\text{A}$ (two independent output)

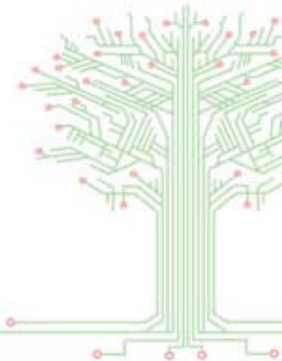

- ❑ Gas Pressure Sensor: AEB025, new PTM
- ❑ MAP Sensor: AEB025, new PTM, Original
- ❑ Gas Temperature Sensor: 4K7, 2k2
- ❑ Water Temperature Sensor: 4K7, Original
- ❑ Gas Level Sensor: AEB, 0-90 Ω , not standard, not standard inverted
- ❑ Lambda Probe: 0-1V, 0-5V, 5-0V, 0.8-1.6V

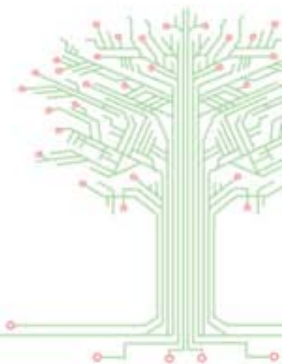

Monoplug vs other ECUs

Feature	AEB2001NC	AEB2001PC	Monoplug
Extended map (12x12)	✓	X	✓
Progressive petrol to gas swicth	✓	✓	✓
Petrol addition management (idle, addition, high RPM)	✓	X	✓
Diagnosys on gas injectors	✓	X	✓
Real time diagnosys on petrol injectors connection	✓	✓	✓
Diagnosys on sensors and change over swicth	✓	✓	✓
Gas injectors enable/disable for diagnostic purpose	✓	X	✓
RPM reading from negative coil or Injection time	✓	X	✓

Monoplug vs other ECUs

Feature	AEB2001NC	AEB2001PC	Monoplug
Split fuel option	✓	X	✓
Start & Stop vehicle management	✓	X	✓
Lambda probe reading and emulation	✓ (two channel)	X (just reading one channel)	✓ (one channel)
Multilayer board	✓	X	✓
Linear Lambda probe emulation	✓	X	X
OBD II parameter reading and visualization	✓	X	X
OBD II Adaptativity	✓	X	X
Low standby current ($I_q < 10\mu A$)	✓	X	X

Interchangeable

- ❑ Compatibility with actual software (V>x.x.x) ✓
- ❑ Compatibility with actual configurations ✓
- ❑ Compatibility with actual kits ✓
- ❑ Compatibility with actual harnesses X
- ❑ Compatibility with actual firmwares X

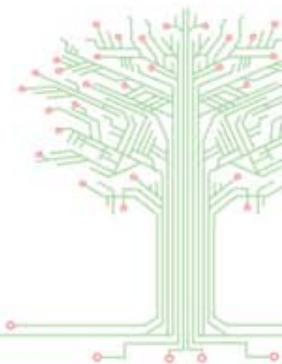

Diagram

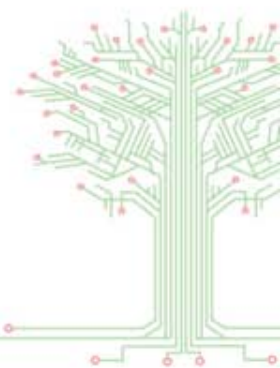
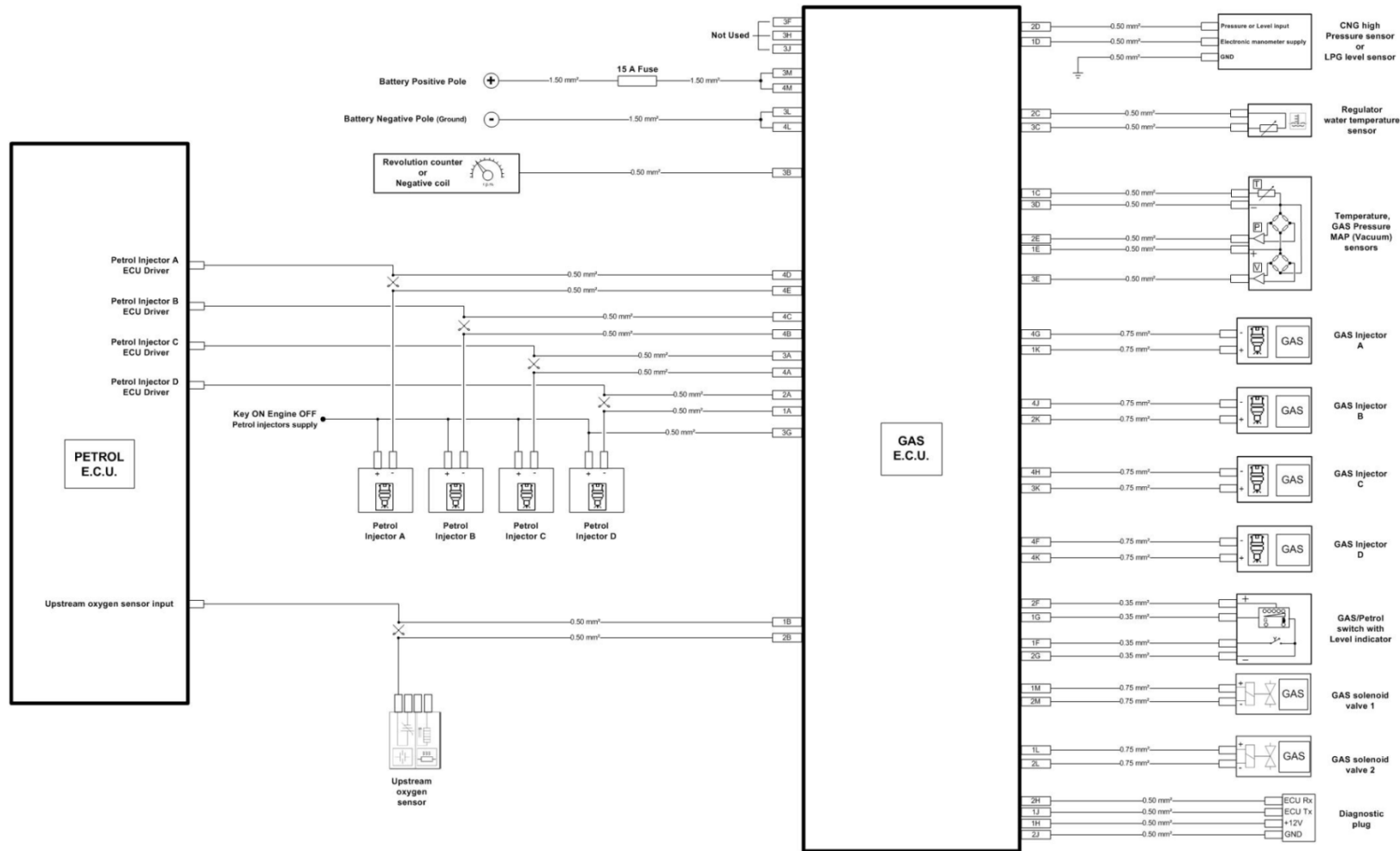

Harness drawing

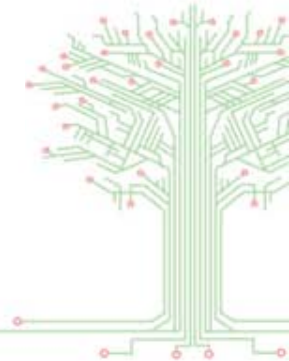
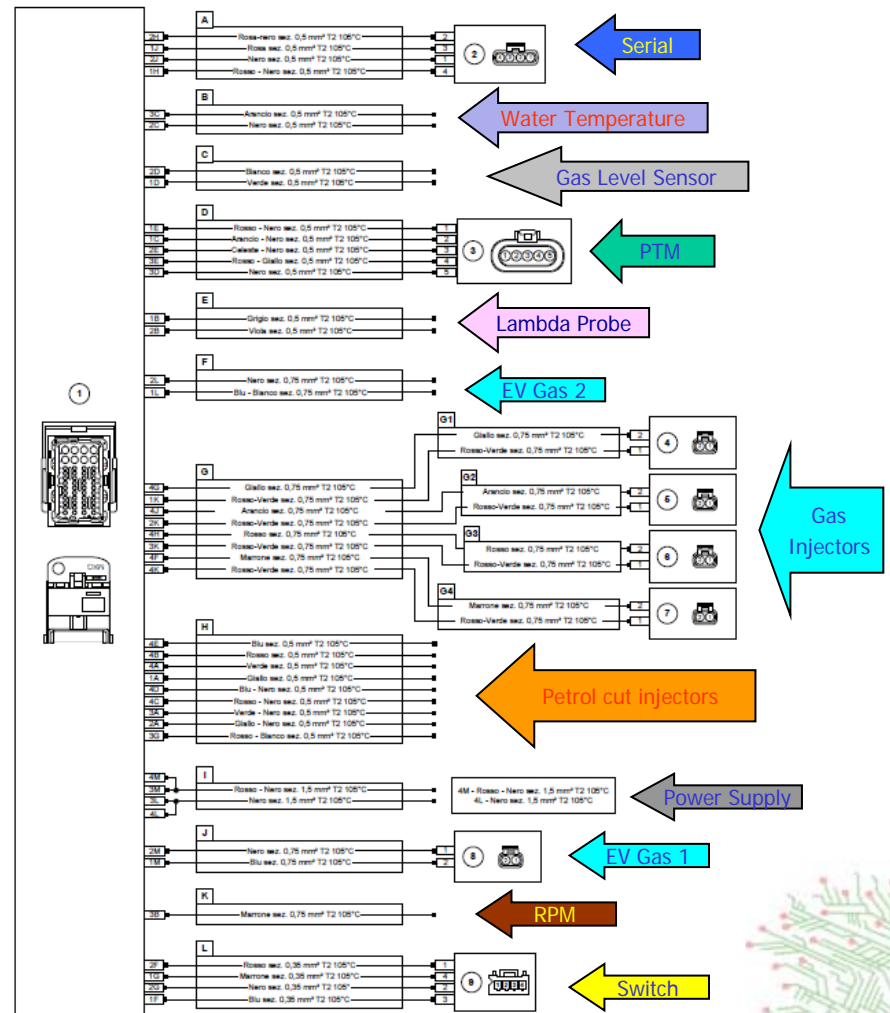
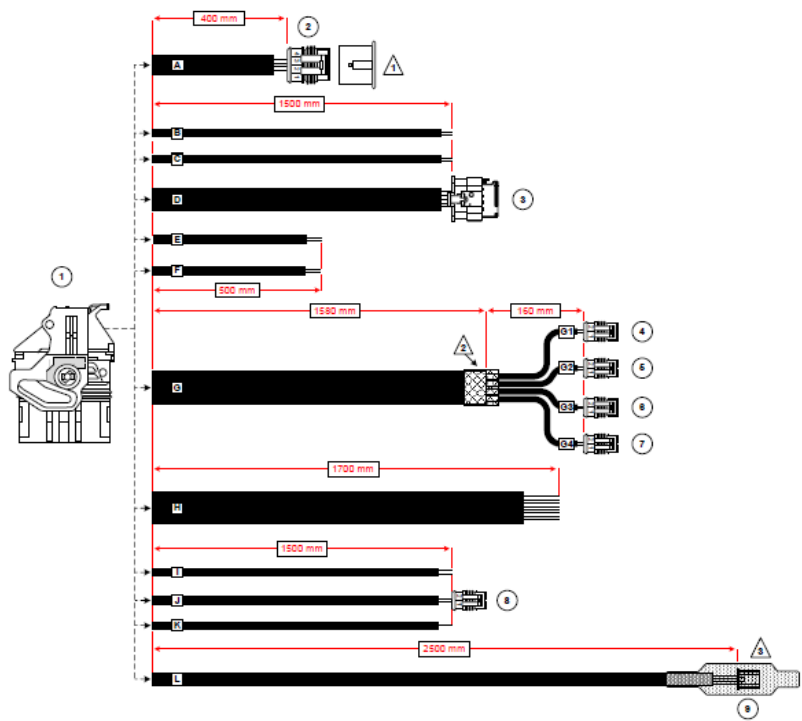

Installation drawing

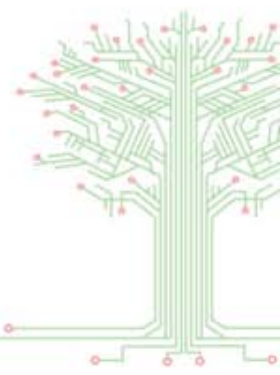
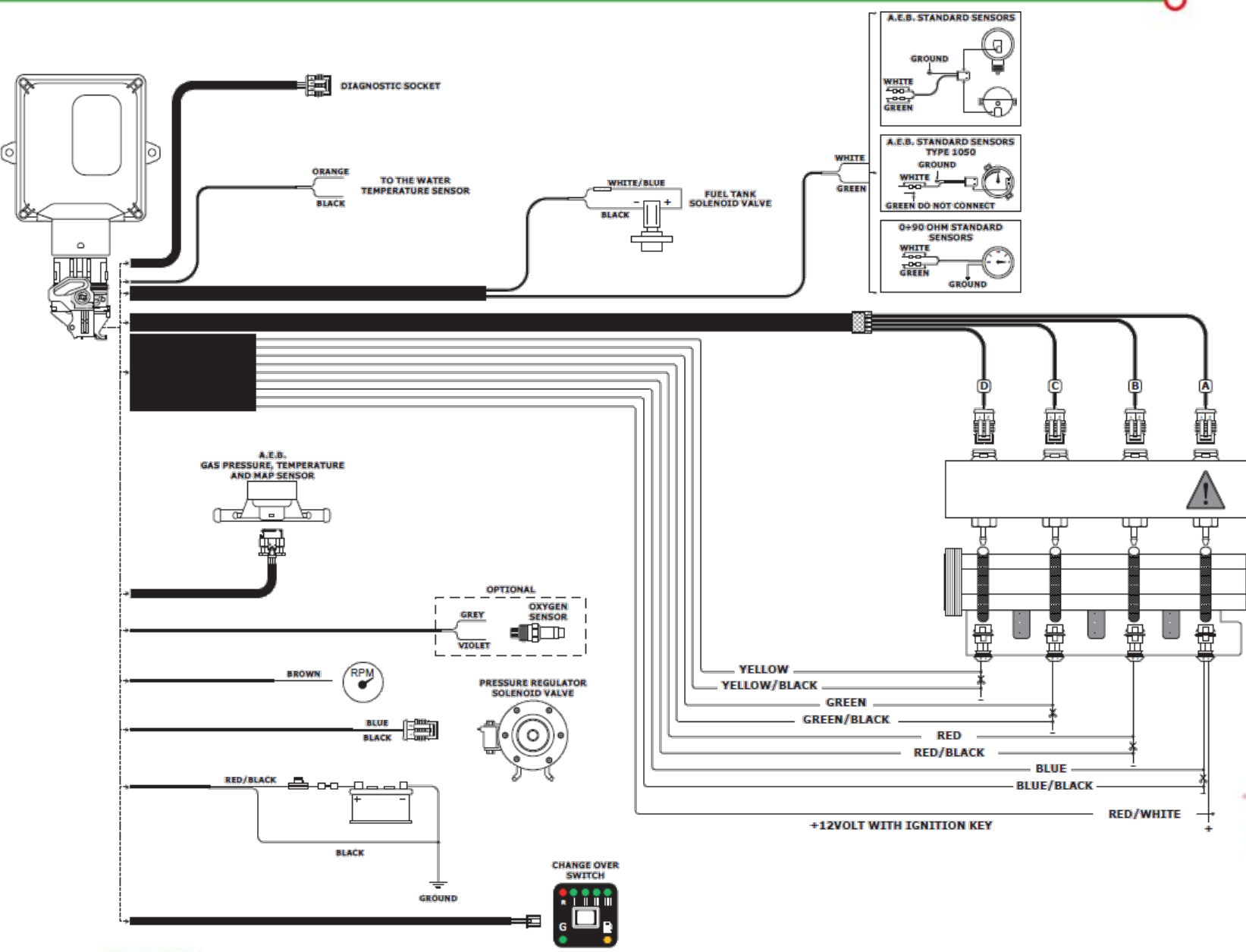

PTM sensor: gas Pressure and Temperature, MAP

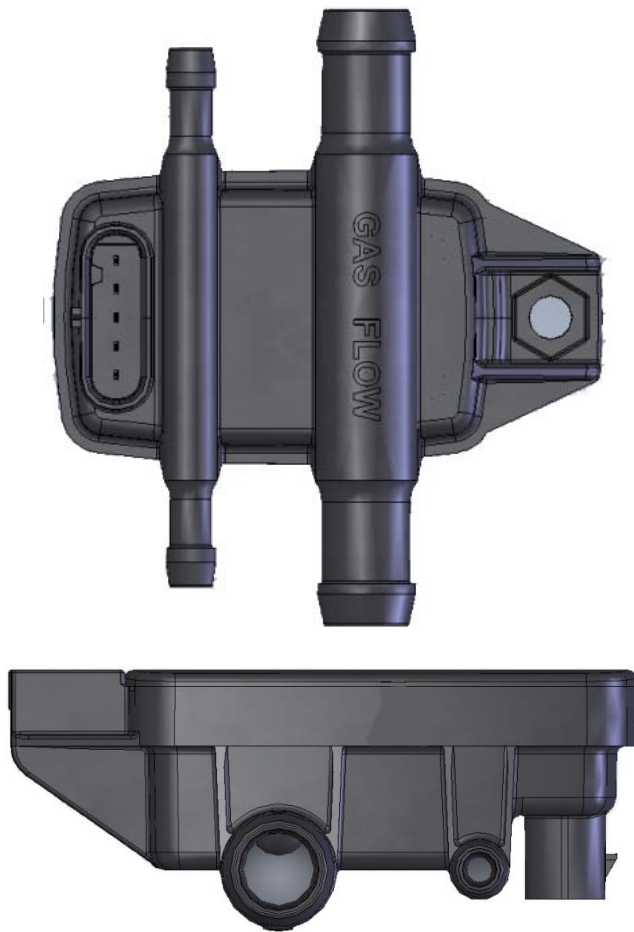

- ❑ GAS Type: LPG/CNG
- ❑ Power Supply: $5 \pm 0.2 \text{ V}$
- ❑ Map signal Output range: $0.5 \div 4.5 \text{ V}$
- ❑ Pressure signal Output range: $0.5 \div 4.5 \text{ V}$
- ❑ Temperature range: $-40 \div 125^\circ\text{C}$
- ❑ Maximum Gas Pressure: 4.5 Bar

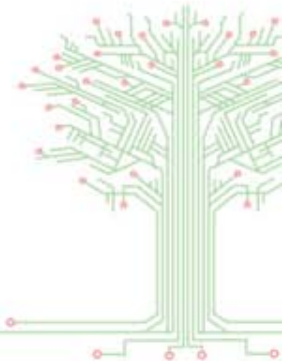

New PTM sensor: Mechanical installation

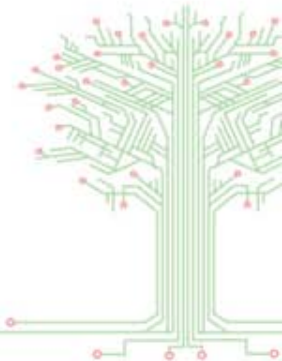
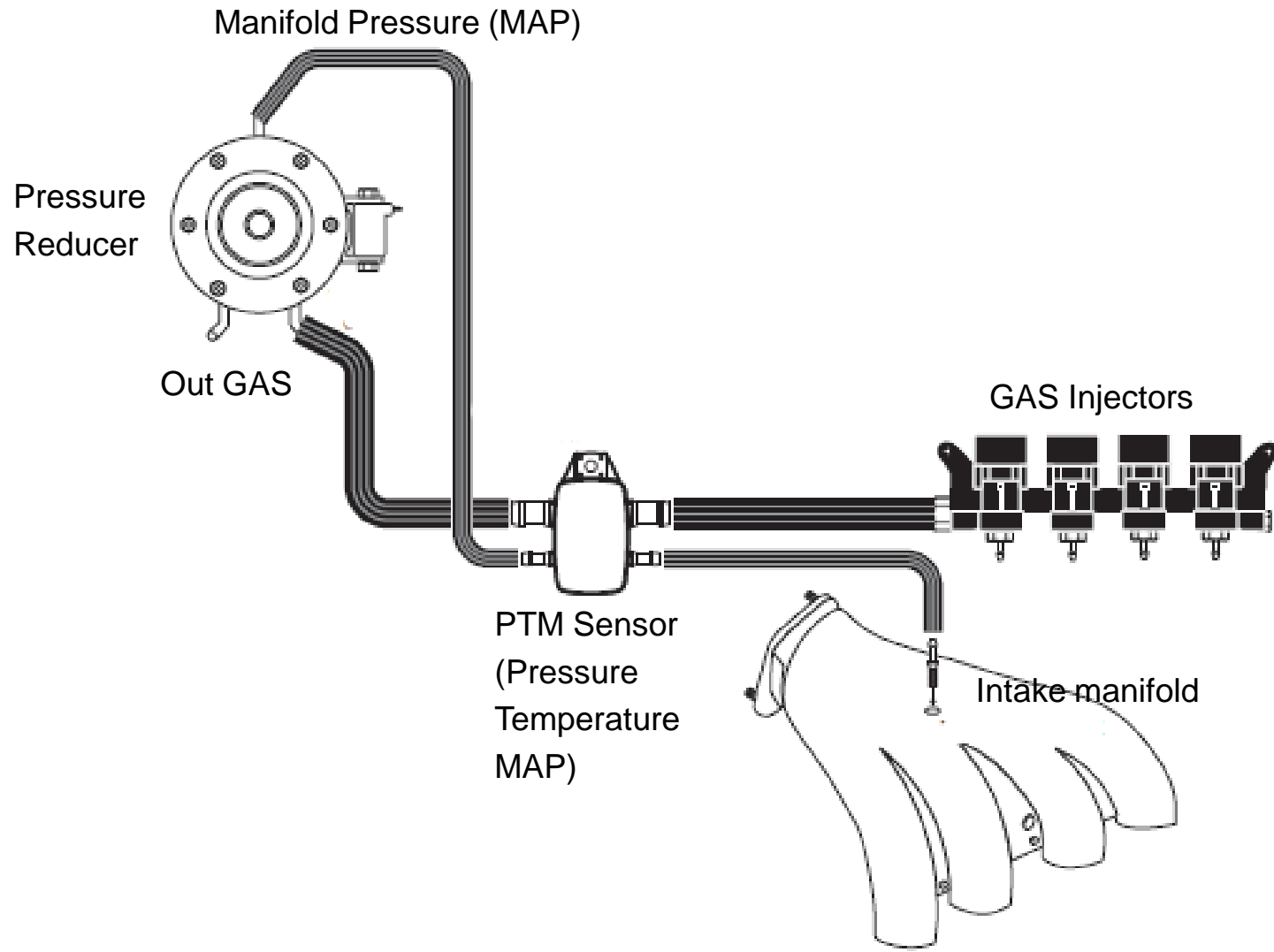

Injectors rail

Highlights

- **Two Injectors families**
 - Aluminum
 - Polymer
- Both version accept different hole size on same body
- High pressure up to 7 bar CNG
- Easy maintenance
- Cost/performance ratio
- Polymer version has better performances (repeatability, cold conditions, endurance)

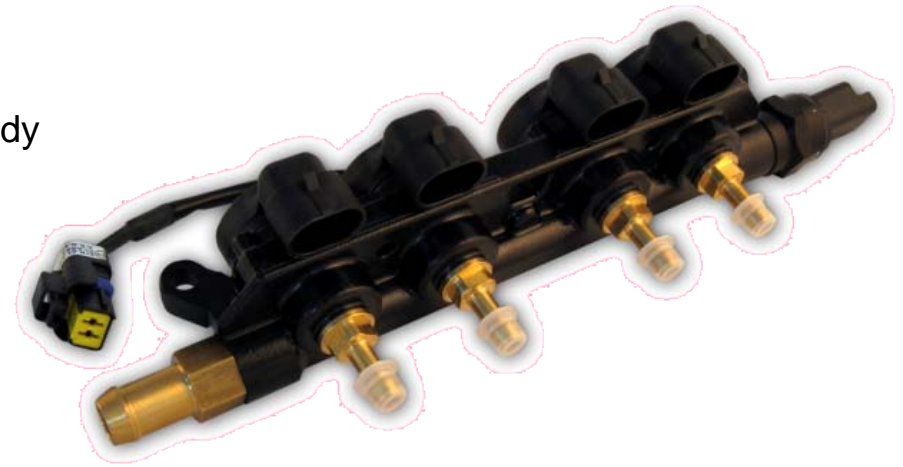

Aluminum version with integrated sensor

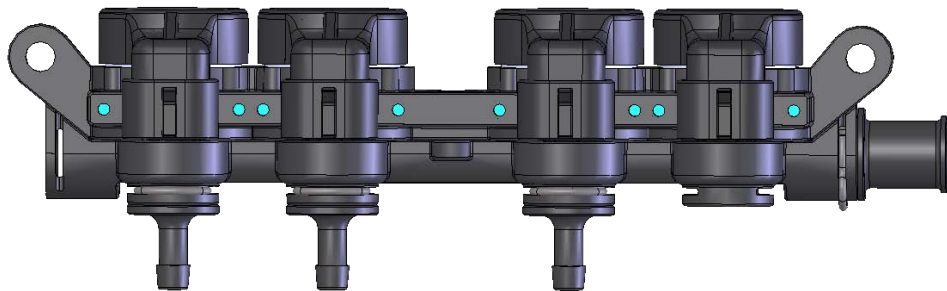

Polymer version

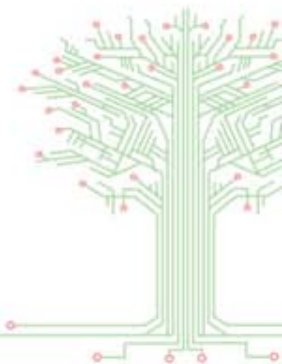

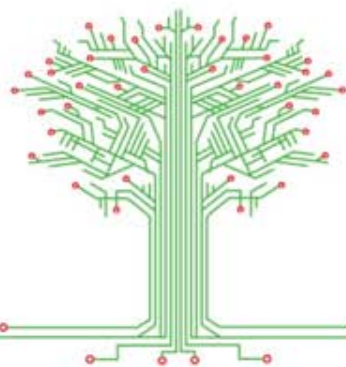

A.E.B. S.P.A. a socio unico

Via dell'Industria 20 | 42025 Cavriago (RE) | Italia
Ph. +39 0522 494401 | fax +39 0522 494410 | info@aeb.it | www.aeb.it